

# ELITE 1000 TOUCH-FREE ELECTRONIC LAVATORY FAUCET

## SPECIFICATIONS

Touch-free electronic faucet for deck-mounted installations. Activated by Infrared sensor. Chrome plated body, other finishes available. Includes a low battery indicator. With mixer for water temperature adjustment for hot and cold water. The Elite line has an Infrared sensor and a solenoid valve inside the body of the product for added vandal resistance. Adjustable settings by remote control: Sensor range, Security time, Delay In, Delay Out and On-Off. 24 hour mandatory hygiene flush can be provided upon request. Compliance certifications: IAMPO (USA), WRAS (UK), VA-ETA (Denmark), SINTEF (Norway)

## OPERATION

Touch-free electronic faucet operated by an infrared sensor. The faucet automatically activates when users place their hands within sensor range and stops when they remove them from the sensor range.

## APPLICATION

Deck-mounted faucet combining an elegant design with anti-vandal features. Helps washrooms cleanliness, saves water and prevents cross contamination. Ideal for transportation hubs, train and bus stations, highway rest stops and stadiums.

## PRODUCT AT A GLANCE

|                    |   |
|--------------------|---|
| Installation       | Lavatory mounted  |
| Power Supply       | <ul style="list-style-type: none"> <li>9V external battery box</li> <li>IP67 Battery Box for 6 AA 1.5V alkaline batteries</li> <li>9V Transformer</li> <li>IP 68 Encapsulated 9V transformer</li> </ul> |
| Operating pressure | 0.5-8.0 bar / 7.0-116.0 PSI   |
| Water supply       | Hot and cold water  |
| Water flow         | 2 lpm / 0.5 gpm   |
| Water temperature  | 70°C Maximum  |
| Security Time      | 90 seconds. Adjustable by remote control  |

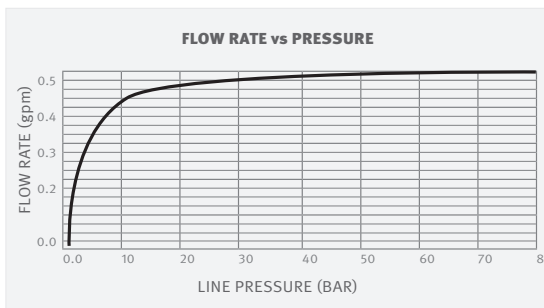

## OPTIONS

| OPTION  | CODE     |
|---|----------|
| Remote control  | 07100005 |
| Matching battery-powered soap dispenser                 | 236100   |
| Matching transformer-powered soap dispenser combination | 236110   |

## ORDERING INFORMATION

| MODEL             | CODE   | POWER          | ADDITIONAL SPECIFICATIONS                            |
|-------------------|--------|----------------|--|
| ELITE 1000 B      | 236700 | 9V battery     | With mixer for water temperature adjustment          |
| ELITE 1000 E      | 236800 | 9V transformer |  |
| ELITE 1000 LB     | 236550 | 9V battery     | Long spout length 138mm \ 5.44"                      |
| ELITE 1000 LE     | 236650 | 9V transformer | With mixer for water temperature adjustment          |
| ELITE 1000 PLUS B | 236750 | 9V battery     | Tall body 338mm \ 13.30" for counter top wash basins |
| ELITE 1000 PLUS E | 236850 | 9V transformer | With mixer for water temperature adjustment          |

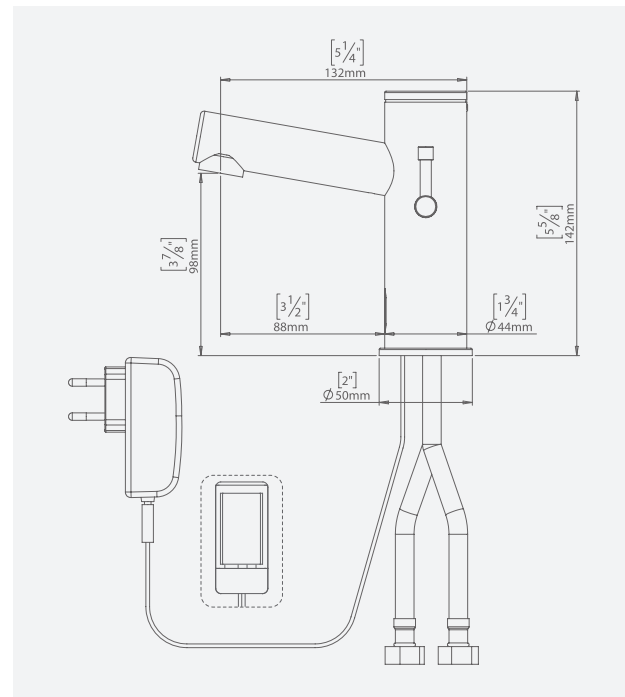

## ADVANTAGES



LEED RATING



OPTIONAL HYGIENE FLUSH



ROBUST BRASS BODY



ADJUSTABLE SETTINGS



EASY TO INSTALL

## APPROVALS



ADA DESIGNED



COMPLIES TO ASME A112.18.1 / CSA B125.1

777 Passaic Avenue  
Clifton NJ, 07012  
USA: sternusa@sternfaucets.com  
International: info@sternfaucets.com  
Toll Free: 1-800-4364410

www.sternfaucets.com