

STERN

STERN ENGINEERING LTD.



TOUCH FREE DECK MOUNTED SOAP DISPENSERS

INSTALLATION AND MAINTENANCE GUIDE

INDEX

1-2	TECHNICAL DATA
3	PRE-INSTALLATION INFO
4	PACK CONTENTS
5-7	INSTALLATION
8	FILLING THE SOAP TANK
9	SETTINGS ADJUSTMENT
10	BATTERY REPLACEMENT
11	SPARE PARTS LIST
12	MAINTENANCE
13	LIMITED WARRANTY
14-15	TROUBLESHOOTING

The information in this document reflects products at the date of printing. Stern Engineering Ltd reserves the right, subject to all applicable laws, at any time, at its sole discretion, and without notice, to discontinue or change the features, designs, materials and other specifications of its products, and to either permanently or temporarily withdraw any of the foregoing from the market. All information in this document is provided "as is" without warranty of any kind, either expressed or implied, including but not limited to any implied warranties of merchantability, fitness for a particular purpose, or non-infringement. Stern Engineering Ltd assumes no responsibility for errors or omissions in the information presented in this document. In no event shall Stern Engineering Ltd be liable for any special, incidental, indirect or consequential damages of any kind, or any damages whatsoever arising out of or in connection with the use or performance of this information. The tradenames, trademarks, logos and service marks presented in this document, including their design, are the property of Stern Engineering Ltd or other third parties and you are not permitted to use them without the prior written consent of Stern Engineering Ltd or such third party as may own them.

TECHNICAL DATA

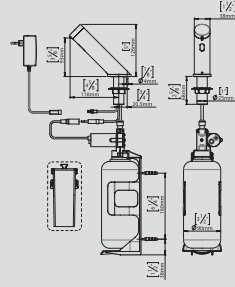
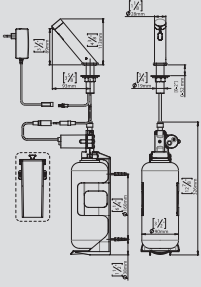
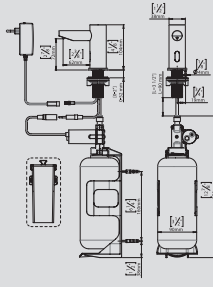
					
GREEN SOAP DISPENSER B	225845	GREEN 28 SOAP DISPENSER B	352900	TRENDY SOAP DISPENSER B	239910
GREEN SOAP DISPENSER E	225840	GREEN 28 SOAP DISPENSER E	352910	TRENDY SOAP DISPENSER E	239900

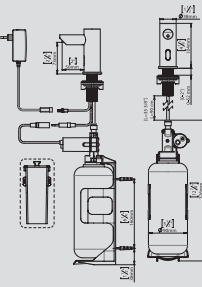
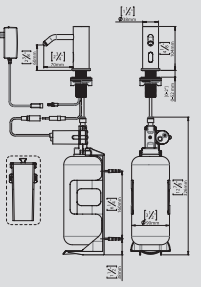
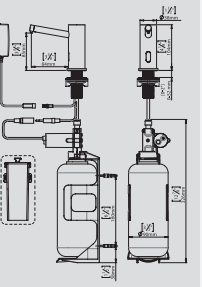
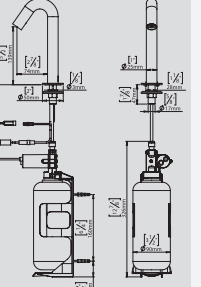
							
SMART SOAP DISPENSER B	235920	EXTREME SOAP DISPENSER B	237920	ELITE SOAP DISPENSER B	236110	CSABA SOAP DISPENSER B	233110
SMART SOAP DISPENSER E	235900	EXTREME SOAP DISPENSER E	237900	ELITE SOAP DISPENSER E	236100	CSABA SOAP DISPENSER E	233100

Capacity	1 Liter / 33.8 oz., or 6 Liters / 1.6 Gallons
Power Supply	Battery Box for 6xD Alkaline batteries or 12V transformer
Soap viscosity	100 – 3800 cPs
Standard discharge	1.4cc (customizable by optional remote control)
Sensor range	30-100 mm +/- 10 mm /1.18-3.94" (customizable by optional remote control)

TECHNICAL DATA

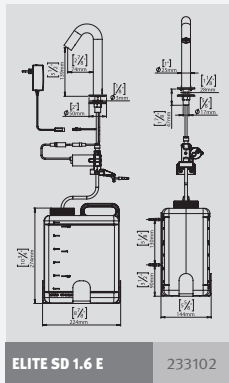
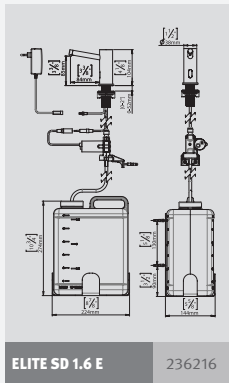
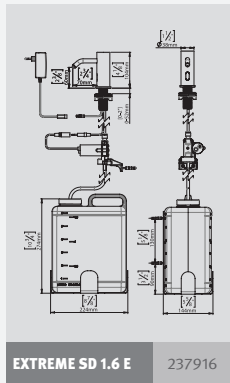
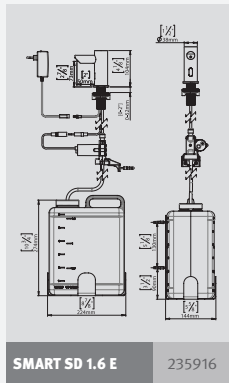
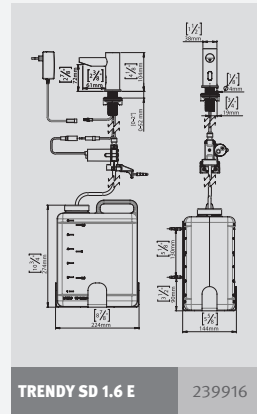
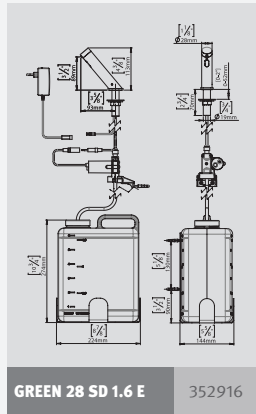
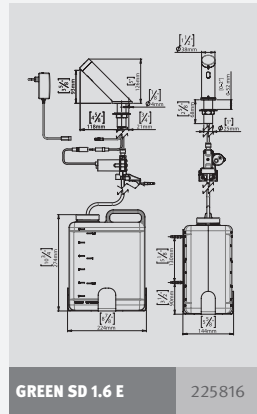

PRE-INSTALLATION INFO

Check contents

Separate all parts from the packaging and check each part with the “Pack contents” section.

Make sure all parts are accounted for before discarding any packaging material.

If any parts are missing, do not attempt to install your touch free soap dispenser until you obtain the missing parts.

Warnings

Do not install the system facing a mirror or any other electronic system operated by an infra-red sensor.

To prevent reflection problems it is recommended to keep a minimum distance of 150 mm between the soap dispenser and any other objects.

IMPORTANT: Keep in mind that when using the faucet installed next to the soap dispenser, the user hands should not interfere with the soap dispenser sensor detection area.

Stern liquid soap dispensers, with proper care, will provide long term trouble free service. Quality liquid soap of recommended viscosity and pH levels are the main factors for smooth operation of your dispenser. If needed, use a viscometer to verify the viscosity of your soap to ensure maximum benefit. The recommended range for liquid soap viscosity is 100-3800 cPs. Thicker liquid soap flows slower and inhibits the pump valve, causing strain and damage.

Stern liquid soap dispensers are suitable for use with any generic liquid soap of the correct viscosity and pH. The pH level of all soap used in Stern liquid soap dispensers should be between 6.5 to 8.5. Lower levels will cause corrosion to the metal dispenser and even the rubber and plastic components. Higher pH levels will cause swelling to rubber parts and degradation of plastic components over time.

PACK CONTENTS

Familiarize yourself with the part names and ensure that all the parts are included in your package.

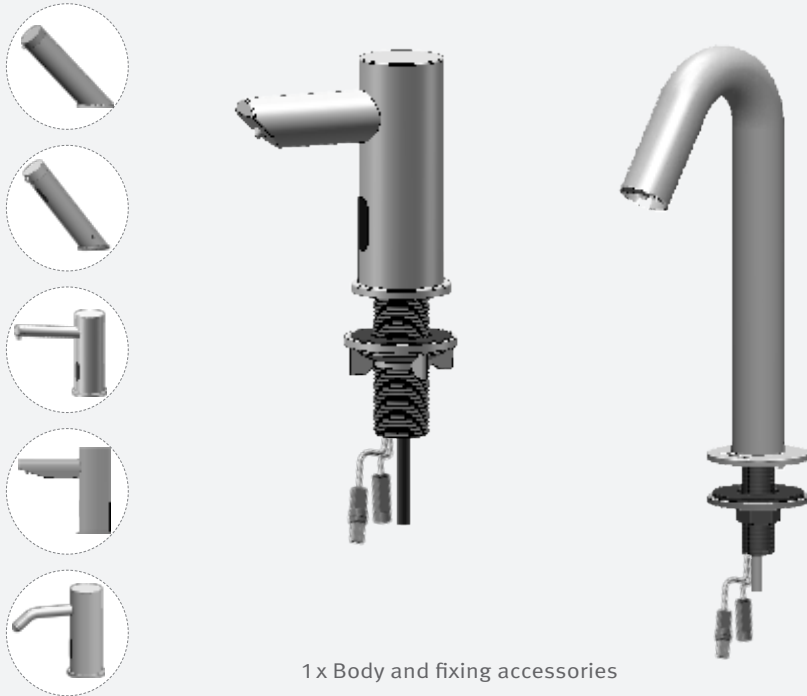

1 x Body and fixing accessories

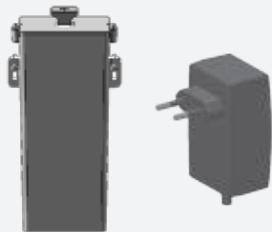

1 x Battery Box for 6xD Alkali batteries / 12V Transformer



1 x Soap tank with bottle support and pump assembly

INSTALLATION

STEP 1 – REMOVE ALL MOUNTING HARDWARE

For TRENDY, ELITE, EXTREME, SMART, GREEN, GREEN 28 Soap Dispensers:

Drill a hole in the deck or lavatory according to the recommended hole size.

Remove the nut, the disk and the gasket from the base of the soap dispenser body.

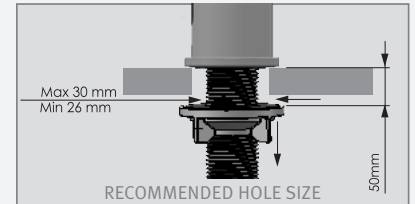

If your dispenser is supplied with anti-rotation solution, drill an additional hole for anti-rotation pin.

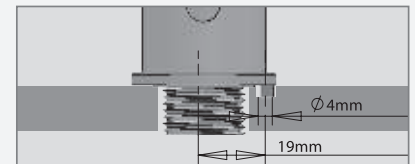

For CSABA Soap Dispenser:

Remove the hexagonal nut, disk and washer. Do not remove the O-ring from the base of the faucet.

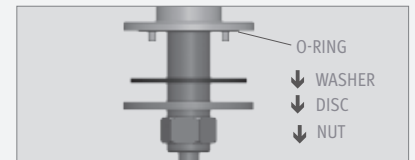

Drill a hole in the counter for the mixing handle. Remove the nut, disk and seal.



STEP 2 – INSTALLING THE SOAP DISPENSER

For TRENDY, ELITE, EXTREME, SMART, GREEN, GREEN 28 Soap Dispensers: Place the soap dispenser body along with the bottom ring into the hole in the deck or lavatory.

Slide the gasket, disk and nut over the soap dispenser body nipple and secure it.

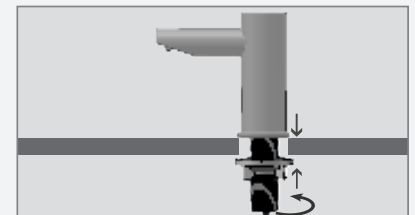



For CSABA Soap Dispenser:

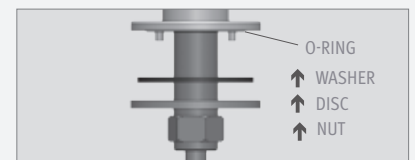

Slide the washer, disk and hexagonal nut over the flexible hose and secure the faucet into place.

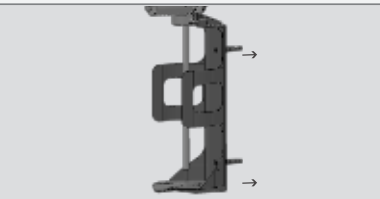
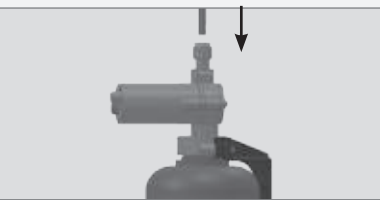
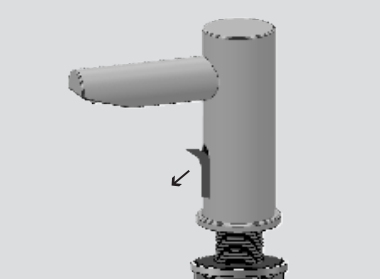
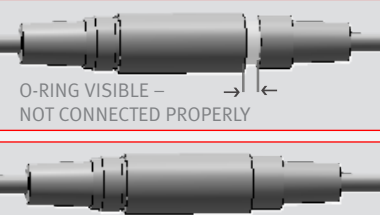

INSTALLATION



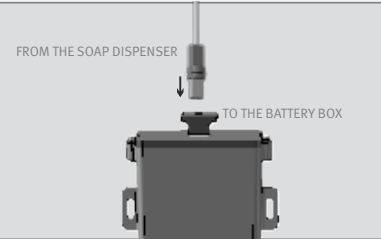
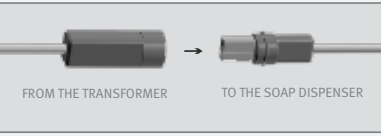

<p>2</p> <p>Fix the bottle with bottle support to the desired location.</p>	
<p>3</p> <p>Snap the soap pipe from the dispenser body into the quick connection fitting of the pump.</p>	
STEP 3 – CONNECTING THE POWER SOURCE	
<p>1</p> <p>Remove the protective sticker covering the sensor. Keep away from the sensor range.</p>	
<p>2</p> <p>Connect the motor connector to its matching connector coming from the electronic unit. Please note that since the connector is water proof, some friction might apply.</p>	 <p>O-RING VISIBLE – NOT CONNECTED PROPERLY</p>  <p>ONLY THE GROOVES ARE VISIBLE – CONNECTED PROPERLY</p>

INSTALLATION

<p>IMPORTANT: the 4 contacts connector should be connected properly so that the white o-ring is not visible and a clicking sound is heard.</p> <p>PAY ATTENTION: If the 4 contacts connectors is not connected properly, the motor will work continuously.</p>	
<p>2a</p> <p>For battery versions: install the battery box on the wall underneath the sink and connect the battery connector.</p> <p>Caution: make sure to connect the connectors according to the indication on the battery box sticker.</p>	 <p>FROM THE SOAP DISPENSER</p> <p>TO THE BATTERY BOX</p>
<p>2b</p> <p>For transformer versions: plug the transformer into the electricity socket and connect the transformer connector</p>	 <p>FROM THE TRANSFORMER</p> <p>TO THE SOAP DISPENSER</p>
<p>3</p> <p>Wait about 10 seconds before you put your hands within the sensor range.</p>	 <p>ABOUT 10 SECONDS</p>

FILLING THE SOAP TANK

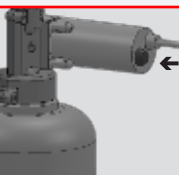
If your model is an MF model, please refer to the Multifeed installation guide.

1	Unscrew the soap tank from the pump assembly and pull it out of the bottle support.	
2	Fill in the liquid soap up to the top line.	
3	Insert the bottle inside the bottle support.	
4	Screw the soap tank back to the pump assembly. Make sure the tank is firmly secured into place.	
5	Press the refill button located at the back of the pump assembly until soap starts coming out of the soap dispenser spout. This operation can also be done using the soap dispenser remote control Refill function.	
6	NOTE: Once the soap in the soap tank has reached the bottom line the soap tank should be refilled. To refill the soap tank please refer to steps 1-5.	

REMOTE CONTROL FUNCTIONS

If you acquired the remote control together with your soap dispenser, you may adjust the dispenser settings if required. To use the remote control hold it straight in front of the sensor at a distance of about 10-15 cm (4-6").

Attention: The remote control held out of the recommended range (too close or too far) will not operate.

The remote control can be used to adjust the following functions:

1-SOAP QUANTITY

The 1-4 drop keys allow the user to choose the desired soap quantity. *

① 0.7 to 0.9	② 1.2 to 1.6	③ 1.6 to 1.9	④ 2.1 to 2.3
--------------	--------------	--------------	--------------

Indication: continuous blinking of the LED in the sensor eye.

*The exact dosage depends on soap viscosity.

2-ADJ

This function resets the sensor back to factory settings.

Indication: 2 blinks of the LED in the sensor eye.

3-TEMPORARY OFF FUNCTION

This function is ideal to perform any kind of activity in front of the sensor without operating the system (for example, cleaning). The soap dispenser will remain shut for one minute when this button is pressed once.

To cancel this function and to return to normal operation press the On/Off button again or wait for one minute.

Indication: OFF – 2 fast blinks, ON – 4 fast blinks

4-FILL THE SOAP TANK

Once the soap tank has been filled / re-filled, press the FILL button. The pump will run for one minute for priming the soap to the soap dispenser spout.

To stop this activity press the FILL button again. If the soap has not started coming out of the spout, press the Fill button again.

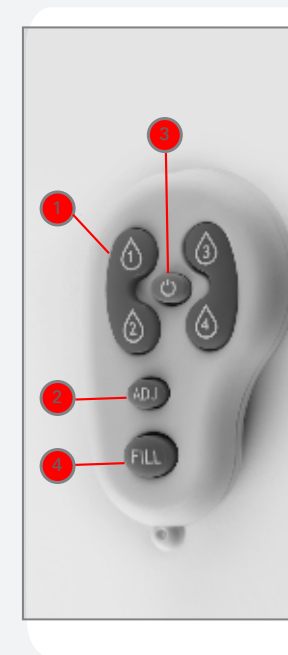

BATTERY REPLACEMENT

Battery models only

When the battery weakens, the red indicator light will blink at a constant rate when the user's hands are within the sensor range. The battery must be replaced within two weeks.

To replace the battery in battery models:

1. Carefully open the battery box, use a 2.5 mm Allen key
2. Remove the old batteries
3. Replace the used batteries with new D batteries
4. Close the box.

NOTE: Do not mix used batteries with new ones.

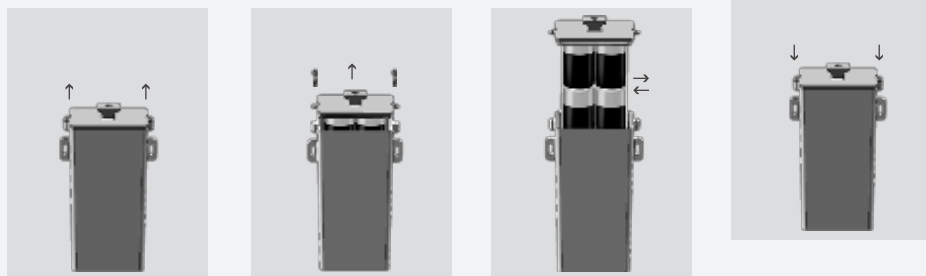

Important: Spent batteries should not be disposed of with normal household waste. Contact your local authority for information on waste disposal and recycling.



SPARE PARTS LIST

SEALS & SCREWS KIT SMART/EXTREME/TRENDY/ELITE SD	07210088
SEALS & SCREWS KIT GREEN SD	07210143
10-PACK SENSOR KIT SMART/EXTREME/TRENDY/ELITE SD	07220279
10-PACK SENSOR KIT GREEN SD	07220303
10-PACK SENSOR KIT CSABA SD	08008005
SOAP DISPENSER PUMP ASSEMBLY	07222028
6-PACK SOAP BOTTLE 1L	07100035
6-PACK SOAP BOTTLE 1L SUPPORT KIT	07100037
BATTERY BOX FOR 6 X D ALKALINE BATTERIES	06530041
12V SWITCHING TRANSFORMER (EU)	06522081
REMOTE CONTROL FOR SOAP DISPENSER (OPTIONAL)	07100008
SOAP & WATER REMOTE CONTROL (OPTIONAL)	07100014

MAINTENANCE

Care and cleaning of chrome and special finishes

DO NOT use steel wool or cleansing agents containing alcohol, acid, abrasives, or the like. Use of any prohibited cleaning or maintenance products or substances could damage the surface of the soap dispenser. For surface cleaning use ONLY soap and water, then wipe dry with a clean cloth or towel. When cleaning bathroom tiles, the soap dispenser should be protected from any splattering of harsh cleansers.

Disassemble of the soap pipe from the pump

The soap pipe can be disconnected from the soap pump by a simple slide & pull action. The sliding ring of the quick connection fixation nipple on the pump should be pulled down. It releases the open end of the soap pipe which can then be easily pulled out.

Clean the soap tank

Clean out the tank prior to refill by flushing warm water through the hoses and pump until clean water is released from the spout. TIP: Keeping a spare tank will enable this process to be completed in a speedy and hygienic manner with minimal downtime.

LIMITED WARRANTY

Y. Stern Engineering Ltd. warrants that its electronic products will be free of defects in material and workmanship during normal use for two years from the date the product is purchased.

If a defect is found in normal use, Y. Stern Engineering Ltd. will, at its discretion, repair, provide a replacement part or product, or make appropriate adjustments. Damage caused by accident, misuse, or abuse is not covered by this warranty. Improper care and cleaning will void the warranty. Proof of purchase (original sales receipt) must be provided to Stern Engineering Ltd. with all warranty claims.









Stern Engineering Ltd is not responsible for labor charges, installation, or other incidental or consequential costs other than those noted above. In no event shall the liability of Stern Engineering Ltd. exceed the purchase price of the product.

If you believe that you have a warranty claim, contact your Stern Distributor, Dealer or Plumbing Contractor. Please be sure to provide all pertinent information regarding your claim, including a complete description of the problem, the product, model number, the date the product was purchased, from whom the product was purchased and the installation date. Also include your original invoice.

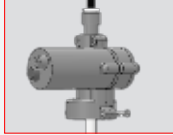
Y. STERN ENGINEERING AND/OR SELLER DISCLAIM ANY LIABILITY FOR SPECIAL, INCIDENTAL OR CONSEQUENTIAL DAMAGES. This warranty excludes product damage due to installation error, incorrect maintenance, wear and tear, battery, product abuse, or product misuse, whether performed by a contractor, service company, or the consumer. This warranty does not cover product damage caused by the following:

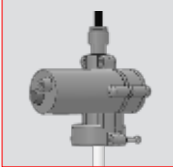
- Incorrect installation.
- Inversions of supply pipes.
- Pressures or temperatures exceeding recommended limits.
- Improper manipulation, tampering, bad or lapsed maintenance.
- Foreign bodies, dirt or scale introduced by the water supply or soap tank.
- Use of the soap outside of viscosity specifications.
- Alteration of the original soap/foam dispenser components (including pipes).

TROUBLESHOOTING

Indication	Investigation	Cause	Solution	Illustration
False activation: Soap dispensing	Continuous discharge from the nozzle	AUX connector not fully inserted	The connector should be inserted fully until white o-ring is not visible. Remove the o-ring if necessary	
	Random discharge from the nozzle	Reflection issue from other object	Eliminate any cause of reflection and if necessary use appropriate remote control to shorten detection range.	
	Soap discharging from pump housing.	Damaged pump due to high viscosity or debris in pipes	Replace the Pump. Rinse warm water through the pipe and the body of the soap dispenser all the way to the nozzle.	
Soap not dispensing	Pump is making sounds when sensor is activated	Soap tank is empty	Fill with soap with correct viscosity (100 - 3800 cPs) and prime pipes using the fill button on remote control.	
		Soap dispenser has not been primed	Prime the soap dispenser by pressing the fill button on the remote or by pressing the refill button located at the bottom of the pump, until soap exits the nozzle.	
		Damaged pump (discharge from housing)	Replace the Pump	
		Debris or dried soap in the pipe or tank	Run warm water through pipe, pump, and body all the way to the nozzle. Replace with soap of correct viscosity.	
		High viscosity soap (> 3800 cPs)	NOTE: Using the soap dispenser with high viscosity soap may cause permanent damage to the pump and shorten the lifecycle.	
		Bent pipes	Unbend or straighten pipes.	

TROUBLESHOOTING

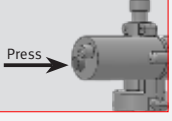
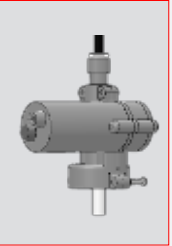
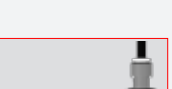
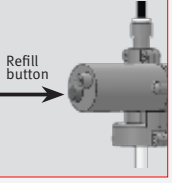
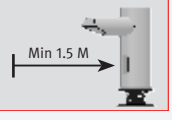
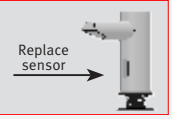
Indication	Investigation	Cause	Solution	Illustration	
Soap not dispensing	Pump is not making sound when the sensor is activated	Sensor is blinking when hand is placed in front	AUX connector not fully inserted	The connector should be inserted fully until the white o-ring is not visible. Remove the o-ring if necessary	
		Refill button on pump does not activate the pump.	Replace the Pump. Rinse warm water through the pipe and the body of the soap dispenser all the way to the nozzle.		
		Damaged pump (discharge from housing).	Replace the Pump. Rinse warm water through the pipe and the body of the soap dispenser all the way to the nozzle.		
		Debris or dried soap in the tank or tubing	Run warm water through pipe, pump, and body all the way to the nozzle. Replace with soap of correct viscosity. NOTE: Using the soap dispenser with high viscosity soap may cause permanent damage to the pump and shorten the lifecycle.		
		Sensor is not blinking when hand is placed in front	Refill button on pump does not activate the pump.	Transformer: Check operation with functioning transformer. Where necessary replace with appropriate transformer. For part numbers see spare parts list. Battery: Check operation with functioning battery pack. Where necessary, replace batteries or replace the battery pack: Battery pack (without batteries)	
		Reflection issue from other object	Eliminate any cause of reflection and use appropriate remote control to shorten detection range.		
Damaged sensor	If the above two solutions have not resolved this issue replace with appropriate sensor. For part numbers see spare parts list.				

stern

STERN ENGINEERING LTD.

777 Passaic Avenue, Clifton NJ, 07012, USA

Tel: +1-973 773 8011 | Fax: +1-973-779-8768

Toll Free: 1-800-4364410

info@sternfaucets.com | tech@sternfaucets.com

