

lino

Wandarmatur Aufputz
Exposed wall valve
Miscelatore a muro
Robinetterie murale

W45

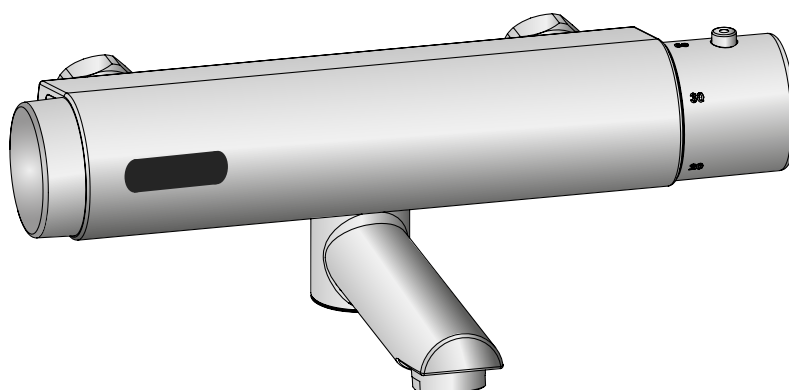

Montage/Bedienungsanleitung
Installation/User manual
Istruzioni di montaggio/per l'uso
Notice d'installation/d'utilisation

- **Richtlinien zur Installation**
- **Direttiva per l' Installazione**

- Wasserleitungsdrücke von Warmwasser und Kaltwasser müssen gleich sein.
- Installation und Lagerung nur in frostsicheren Räumen.

- The water pressure for both the hot and cold water pipes should be equal.
- Install and store in frost-proof rooms only.

- Ab Datum des Erwerbes (Kaufbeleg) gewähren wir eine Garantie von 2 Jahren.

- We will guarantee the products for 2 years from the date of acquisition.

- **Installation guidelines**
- **Directives d'installation**

- Si prega di osservare le norme esistenti per l'installazione e l'allacciamento all'impianto idrico.
- Si consiglia l'installazione con pressioni dell'acqua calde e fredda equilibrate.

- Respecter les normes en vigueur et les conditions de raccordement au réseau d'eau local.
- L'eau chaude et l'eau froide doivent avoir la même pression.

- Garantiamo il prodotto per 2 anni dalla data di acquisto.

- Nous accordons une garantie de 2 ans sur les produits à partir de la date d'achat (ticket de caisse).

- **Installation**
- **Installazione**

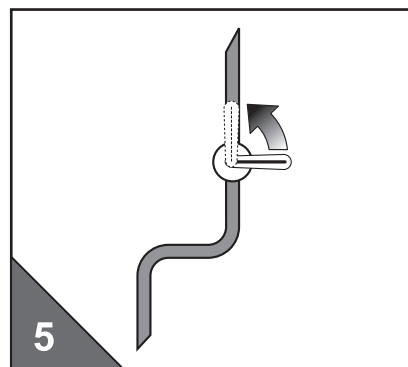
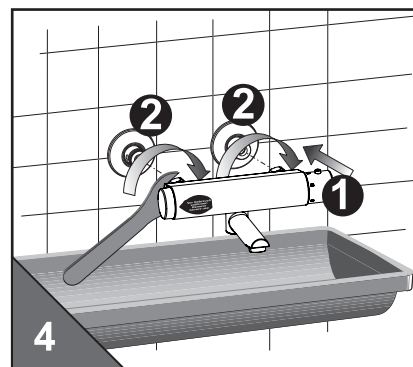
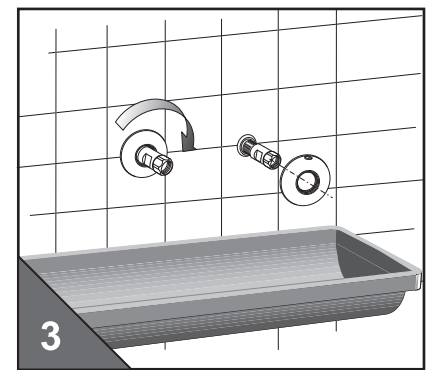
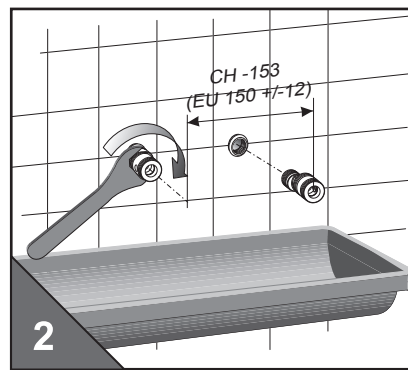
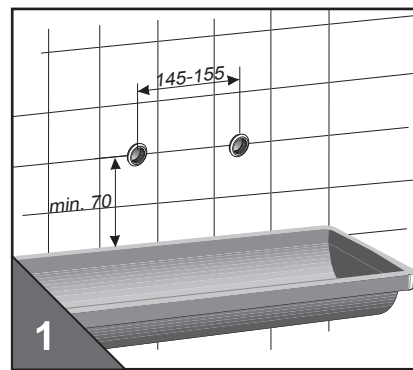

- **Installation**
- **Installation**

- Inbetriebnahme
- Messa in funzione

- Preparing for operation
- Mise en service

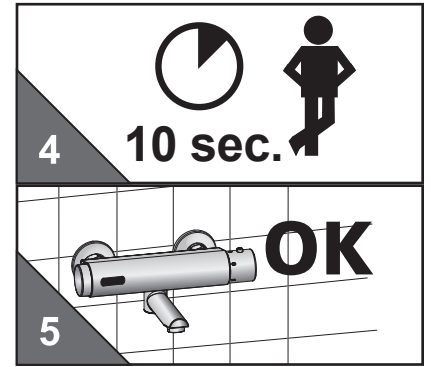
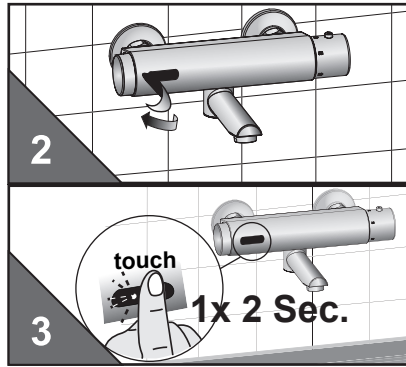
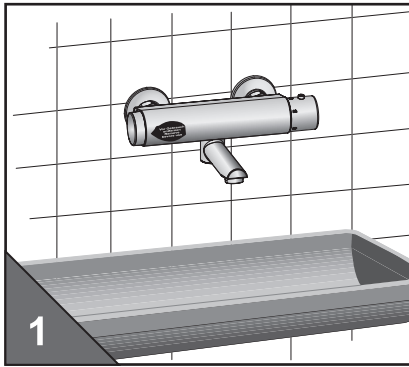

- Funktionen
- Funzioni

- Functions
- Fonctions

- Wasser „Ein“
- Water flow „On“
- Flusso aperto
- Ecoulement ouvert

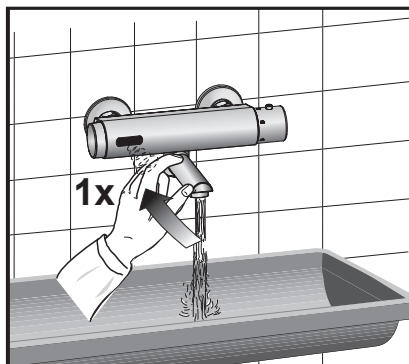

- Wasser „Aus“
- Water flow „Off“
- Flusso chiuso
- Ecoulement fermé

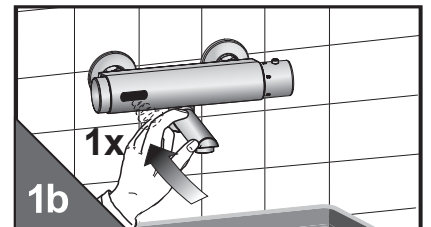
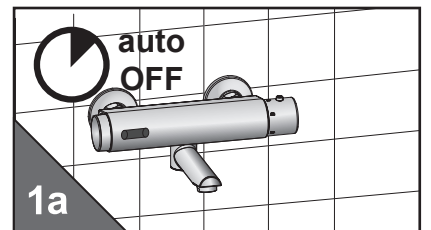

- Temperatureinstellung
- Impostazione della temperatura

- Adjusting the temperature
- Réglage de la température

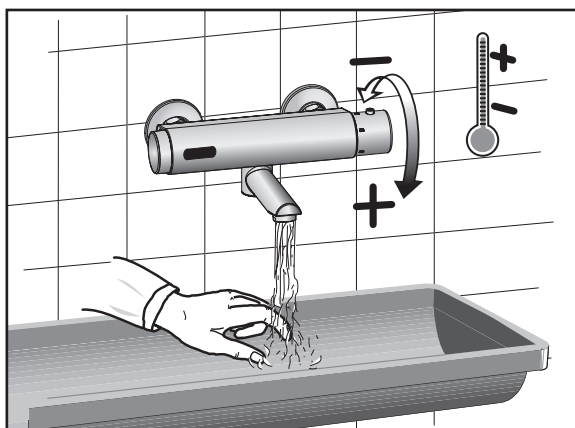

Elektronikfunktionen - Waschtischarmatur berührungslos mit Start/Stop

Zeichenerklärung	☉ - Touch drücken	☞ - Hand/Objekt im Sensorbereich
	💧💧💧 - Wasser fließt	① - LED-Anzeige leuchtet / blinkt GRÜN
	XXX - Wasser aus	② - LED-Anzeige leuchtet / blinkt ROT
	h - Stunden / Min. - Minuten / Sek. - Sekunden	

Funktion	Vorgehensweise	Anzeige Armatur	Zusatzinformation	Werkseitig	Einstellbereich über Touch
Inbetriebnahme nach Installation	1x ☞ min. 3 Sek. bis warten	💧💧💧	Hand/Objekt aus Sensorbereich entfernen	-	-
	warten	② + 💧💧💧	② 2x/Sek., nicht in den Sensorbereich fassen		
	warten bis	① 1x	Bestätigung, Armatur Betriebsbereit		
Kurz-Aus «Pause» aktivieren	1x ☉ ca. 2 Sek. bis	① 1x	Erweiterter Funktionsmodus aktiv	2 Min.	-
	2x ☉ à ca. 0,5 Sek.	②	② pulsiert während Funktion aktiv		
Kurz-Aus «Pause» abbrechen	1x ☉ ca. 2 Sek.	① 1x	manuell vorzeitig abbrechen	2 Min.	-
	oder automatisch	① 1x	automatisch nach eingestellter Zeit		
Dauer-Ein aktivieren	1x ☉ ca. 2 Sek. bis	① 1x	Erweiterter Funktionsmodus aktiv	2 Min.	0,5-20 Min. (in 0,5 Min. Stufen)
	1x ☉ Minimum 3 Sek. (max. 5 Sek.)	💧💧💧	Wasser fließt nach loslassen		
Dauer-Ein abbrechen	1x ☉ ca. 2 Sek.	XXX	manuell vorzeitig abbrechen	2 Min.	0,5-20 Min. (in 0,5 Min. Stufen)
	oder automatisch	XXX	automatisch nach eingestellter Zeit		
Wasserlaufzeit einstellen (Normalfunktion)	1x ☉ ca. 2 Sek. bis	① 1x	Erweiterter Funktionsmodus aktiv	7 Sek.	1-30 Sek.
	1x ☉ ca. 5 Sek. bis	② 1x			
	1x ☉ 1 - 30 Sek. gedrückt halten	② + 💧💧💧	② 1x/Sek., Wasser fließt während Drücken, loslassen bestimmt Wassernachlaufzeit		
	nach loslassen	① 1x	Bestätigung, Armatur Betriebsbereit		
Wasserlaufzeit Dauer-Ein und Wasserlaufzeit Hygienespülung einstellen	1x ☉ ca. 2 Sek. bis	① 1x	Erweiterter Funktionsmodus aktiv	2 Min.	0,5-20 Min. (in 0,5 Min. Stufen)
	1x ☉ Minimum 3 Sek. (max. 5 Sek.)	💧💧💧 + ①	max. 5 Sek. drücken, Wasser fließt nach loslassen		
	1x ☉ gedrückt halten bis	② 1x - 40x	1x ② =0,5 Min. 40x ② = 20,0 Min. loslassen bestimmt Länge der Wasserlaufzeit		
nach loslassen	② + ① 1x	Kontrolle / Bestätigung der Einstellung durch Anzahl ② (1x - 40x) entsprechend vorgenommener Einstellung			
Hygienespülung aktivieren / deaktivieren	1x ☉ ca. 2 Sek. bis	① 1x	Erweiterter Funktionsmodus aktiv	off	off 12 h 24 h 48 h
	1x ☉ ca. 25 Sek. bis	② 1x - 4x	② 1x= off, ② 2x=12h, ② 3x= 24h, ② 4x= 48h Blinkzeichen nach 5 Sek und 10 Sek. nicht beachten - gedrückt halten bis ② 1x - 4x nach ca. 25 Sek., loslassen bestimmt das Hygienespülintervall		
	warten bis	① 1x	Bestätigung, Armatur Betriebsbereit		
Neustart mit Sensoreinmessung	1x ☉ ca. 2 Sek. bis	① 1x	Erweiterter Funktionsmodus aktiv	-	-
	2x ☉ a ca. 0,5 Sek.	②	② pulsiert während Funktion aktiv		
	1x ☉ ca. 5 Sek. bis	② 4x	② 1x/Sek.		
	loslassen und warten bis	② + 💧💧💧	② 1x/Sek., nicht in den Sensorbereich fassen		
	warten bis	① 1x	Bestätigung, Armatur Betriebsbereit		
Batterie-Leer	☞	②	② 2x/Sek. bei Objekterkennung	-	-

washbasin faucet touchless with start/stop function

signs and symbols	☉ - touch function		✋ - hand/object within sensor area
	💧 - water flows		① - LED flashes GREEN
	XXX - waterflow stops		② - LED flashes RED
	h - hours / min. - minutes / sec. - seconds		

function	procedure	feedback signal	information	default	setting range via „touch“
first startup after installation	1x ✋ min. 3 sec. till	💧	remove hand/object from sensor area	-	-
	wait	② + 💧	② 2x/sec., keep out of sensor area		
	wait till	① 1x	confirmation, ready for operation		
temporary off «cleaning mode» activate	1x ☉ app. 2 sec. till	① 1x	extended function mode is active	2 min.	-
	2x ☉ a app. 0,5 sec.	②	② pulsing during active function		
temporary off stop	1x ☉ app. 2 sec.	① 1x	manual stop	-	-
	or automatic	① 1x	automatic after preset time		
continous run activate	1x ☉ app. 2 sec. till	① 1x	extended function mode is active	2 min.	0,5-20 min. (in 0,5 min. steps)
	1x ☉ minimum 3 sec. (max. 5 sec.)	💧	water flows after releasing		
continous run stop	1x ☉ app. 2 sec.	XXX	manual stop	-	-
	or automatic	XXX	automatic after preset time		
follow up time control for normal operation set / programm	1x ☉ app. 2 sec. till	① 1x	extended function mode is active	7 sec.	0-30 sec.
	1x ☉ app. 5 sec. till	② 1x			
	1x ☉ 0 - 30 sec. keep touched	② + 💧	② 1x/sec., water flows during touching - releasing defines duration		
	after releasing	① 1x	confirmation, ready for operation		
time of waterflow for continous on and purge duration for line purge feature set / programm	1x ☉ app. 2 sec. till	① 1x	extended function mode is active	2 min.	0,5-20 min. (in 0,5 min. steps)
	1x ☉ minimum 3 sec. (max. 5 sec.)	💧 + ①	touch max. 5 sec., water flows after releasing		
	1x ☉ keep touched till	② 1x - 40x	1x ② =0,5 min. 40x ② = 20,0 min. releasing defines duration		
	after releasing	② + ① 1x	check / confirmation of setting by repeating number of ② (1x - 40x) according to setting		
line purge feature activate / deactivate	1x ☉ app. 2 sec. till	① 1x	extended function mode is active	off	off 12 h 24 h 48 h
	1x ☉ app. 25 sec. till	② 1x - 4x	② 1x= off, ② 2x=12h, ② 3x= 24h, ② 4x= 48h ignore flashes after 5 sec. and 10 sec. - keep touched till ② 1x - 4x after app. 25 sec., releasing defines interval		
	wait till	① 1x	confirmation, ready for operation		
restart electronics	1x ☉ app. 2 sec. till	① 1x	extended function mode is active	-	-
	2x ☉ a app. 0,5 sec.	②	② pulsing during active function		
	1x ☉ app. 5 sec. till	② 4x	② 1x/sec.		
	release and wait till	② + 💧	② 1x/sec., keep out of sensor area		
	wait till	① 1x	confirmation, ready for operation		
empty battery	✋	②	② 2x/sec. during dedecting hand / object	-	-

- Schmutzsieb-Reinigung
- Pulire il filtro

- Cleaning the filters
- Nettoyage du tamis

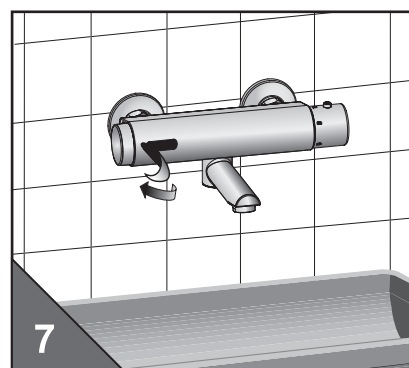
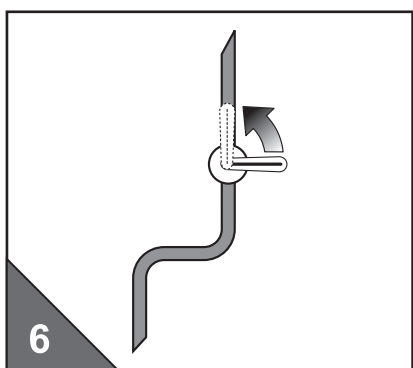
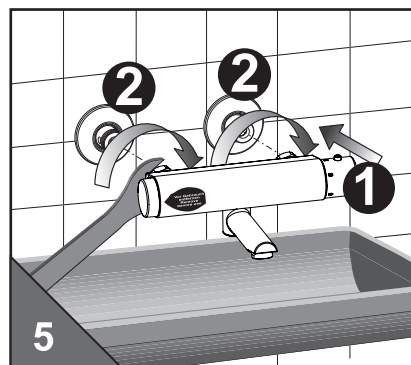
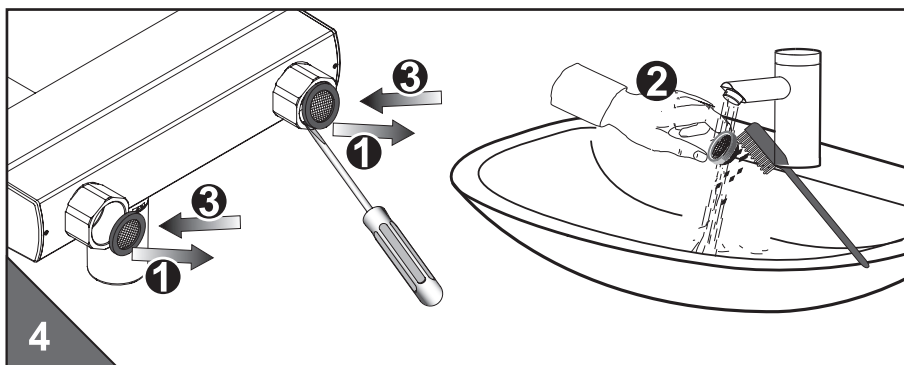
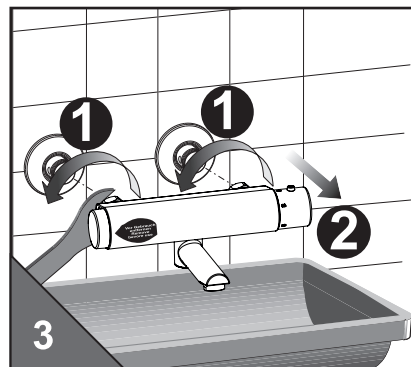
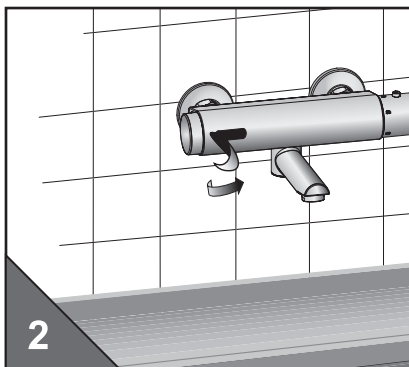
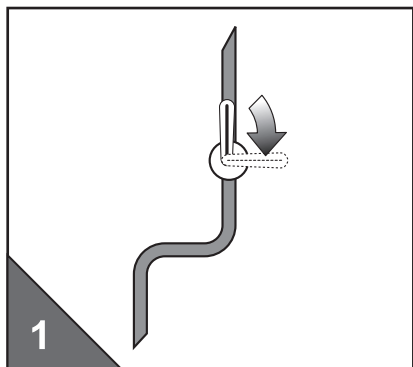

- Batteriewechsel
- Cambio batteria

- Changing the battery
- Remplacer la pile

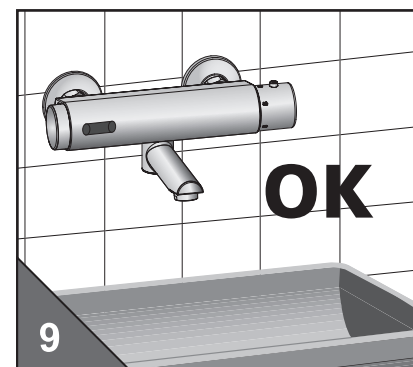
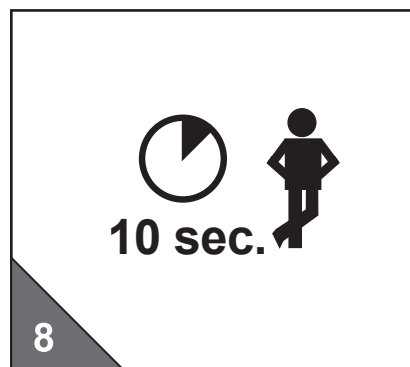
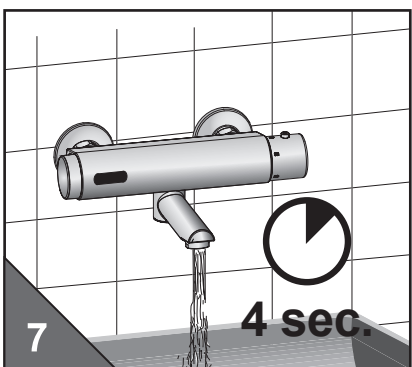
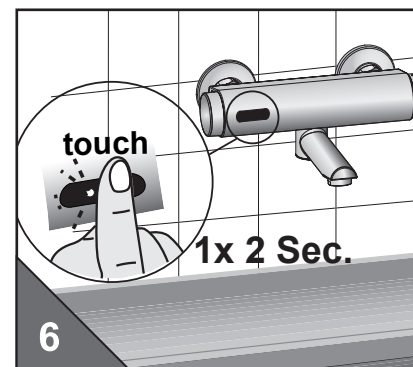
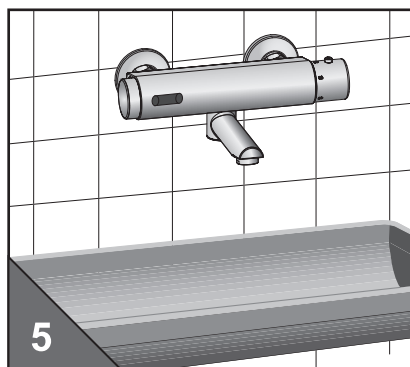
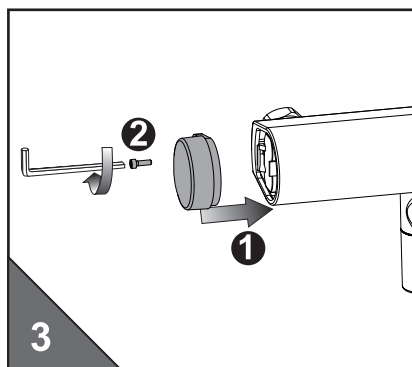
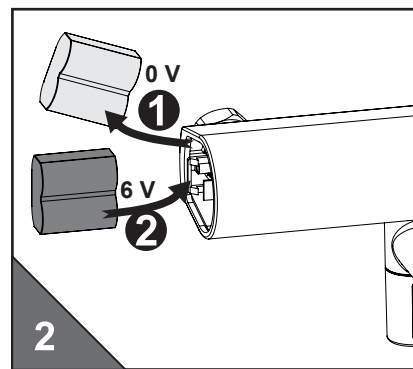
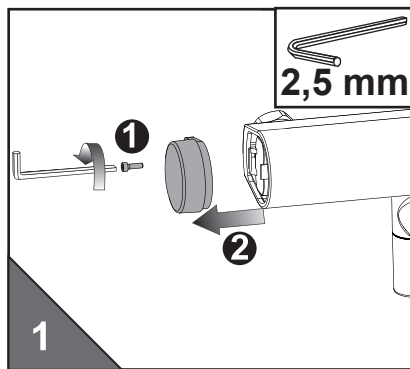
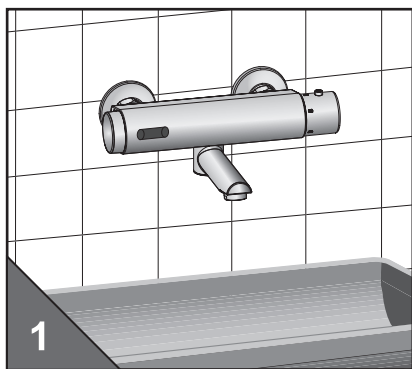

- Systemübersicht
- Vista generale del sistema

- System overview
- Résumé du système

• Technische Daten • Technical Data • Dati tecnici • Données techniques

Batteriebetrieb	Battery operation	Funzionamento a batterie	Fonctionnement sur batterie	6VDC
Netzbetrieb	Mains supply	Funzionamento con alimentazione di rete	Fonctionnement sur secteur	230VAC / 6VDC
Betriebsdruck	Operating pressure pressure	Pressione di esercizio	Pression de service	0,3 - 10 bar
Durchflussmenge	Flow volume	Portata	Débit	ca. 6,5 l/min (3bar)
Wassertemperatur	Water temperature	Temperatura dell'acqua	Température de l'eau	max. 80 °C
Wassernachlaufzeit (Werkseinstellung)	Follow up time (factory setting)	Tempo di coda dell'acqua (impostazione di fabbrica)	Post-écoulement de l'eau (réglage d'usine)	7 sec
Hygienespülung	automatic flush			0/12h/24h/48h

• Störungsbehebung

Störung/Fehler	Mögliche Ursache	Behebung
Es fließt kein Wasser	<ul style="list-style-type: none"> • „Kurz-Aus“ ist aktiviert • Absperrventil geschlossen • Schmutzsieb verstopft • Batterie leer • Stromausfall / Netzteil defekt 	<ul style="list-style-type: none"> • „Kurz-Aus“ beenden • Absperrventil öffnen • Schmutzsieb reinigen • Batterie austauschen • Stromversorgung prüfen
Amatur spült selbständig (ohne Benutzung)	<ul style="list-style-type: none"> • Reflexion an Gegenständen 	<ul style="list-style-type: none"> • Automatische Einmessung • Einstellung der Sensorreichweite
Wasser fließt permanent	<ul style="list-style-type: none"> • Ventil verschmutzt / defekt 	<ul style="list-style-type: none"> • Ventil reinigen / erneuern
Rote LED blinkt	<ul style="list-style-type: none"> • Batterie leer 	<ul style="list-style-type: none"> • Batterie austauschen

• Trouble shooting

Disturbance / Error	Cause	Solution
Valve does not flush	<ul style="list-style-type: none"> • „Intermittent off“ is activated • Stop valve closed or filter clogged • Battery flat • Power failure 	<ul style="list-style-type: none"> • End „intermittent off“ • Open stop valve or clean filter • Change battery • Check power supply
Valve flushes uncontrolled (without use)	<ul style="list-style-type: none"> • Reflection 	<ul style="list-style-type: none"> • Automatic sensor adjustment • Setting the sesor range
Water flows permanently	<ul style="list-style-type: none"> • Valve soiled / defect 	<ul style="list-style-type: none"> • Clean / Renew the valve
Red LED flashes	<ul style="list-style-type: none"> • Battery flat 	<ul style="list-style-type: none"> • Change battery

• Difetti di funzionamento

Difetto / Errore	Possibili causa	Soluzioni
L'orinatoio non sciacqua	<ul style="list-style-type: none"> • „Arresto temporaneo“ attivato • Valvola d'intercettazione chiusa o filtro intasato • Batteria esaurita • Breve interruzione di corrente 	<ul style="list-style-type: none"> • „Arresto temporaneo“ terminato • Aprire la valvola d'intercettazione o pulire il filtro • Cambiare la batteria • Verificare l'alimentazione elettrica
L'orinatoio si attiva autonomamente (senza essere stato usato)	<ul style="list-style-type: none"> • Riflesso 	<ul style="list-style-type: none"> • Misurazione automatica • Impostazione della portata del sensore
L'acqua scorre continuamente	<ul style="list-style-type: none"> • Valvola sporca / difettosa 	<ul style="list-style-type: none"> • Pulito / Rinnovi la valvola
LED rosso lampeggia	<ul style="list-style-type: none"> • Batteria esaurita 	<ul style="list-style-type: none"> • Cambiare la batteria

• Elimination des perturbations

Perturbation / Erreur	Cause possible	Solution
Aucun déclenchement	<ul style="list-style-type: none"> • „Arrêt bref“ activé • Soupape d'arrêt fermée ou tamis bouché • Pile usée • Panne de courant 	<ul style="list-style-type: none"> • Terminer „Arrêt bref“ • Ouvrir la soupape d'arrêt ou nettoyer le tamis • Remplacer la pile • Contrôler l'alimentation en courant
L'eau coule d'elle-même (sans que l'urinoir soit utilisé)	<ul style="list-style-type: none"> • Reflet 	<ul style="list-style-type: none"> • Réglage automatique de la cellule • Réglage de la portée du détecteur
L'eau coule en permanence	<ul style="list-style-type: none"> • Soupape encrassée / défectueuse 	<ul style="list-style-type: none"> • Nettoyer / Nover la soupape
La DEL rouge clignote	<ul style="list-style-type: none"> • Pile usée 	<ul style="list-style-type: none"> • Remplacer la pile

• Pflege • Maintenance • Cura • Entretien holdelse

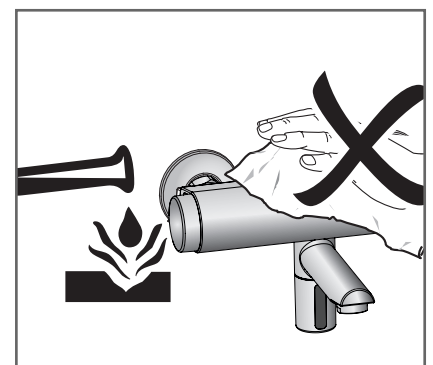
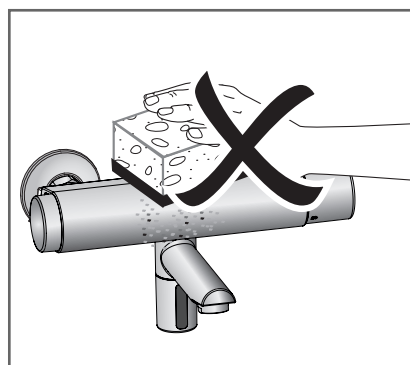
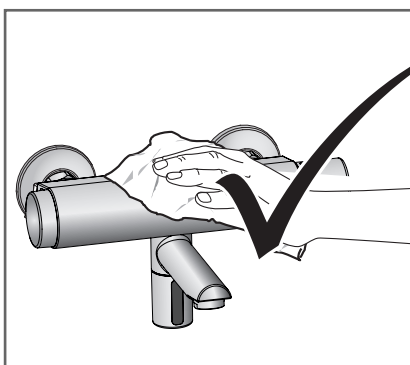

CONTI Sanitärarmaturen GmbH

Hauptstrasse 98
35435 Wettenberg
Germany
info@conti.plus
www.conti.plus

