

# stern

STERN ENGINEERING LTD.



## CSABA SERIES

ELECTRONIC LAVATORY FAUCET

INSTALLATION AND MAINTENANCE GUIDE

# INDEX

1	TECHNICAL DATA
2	PACK CONTENTS
3	PRE-INSTALLATION INFO
4-5	INSTALLATION
6-8	SETTINGS ADJUSTMENT
9	MAINTENANCE
9	BATTERY REPLACEMENT
10	SPARE PARTS LIST
11	LIMITED WARRANTY
12	TROUBLESHOOTING

The information in this document reflects products at the date of printing. Stern Engineering Ltd reserves the right, subject to all applicable laws, at any time, at its sole discretion, and without notice, to discontinue or change the features, designs, materials and other specifications of its products, and to either permanently or temporarily withdraw any of the foregoing from the market. All information in this document is provided "as is" without warranty of any kind, either expressed or implied, including but not limited to any implied warranties of merchantability, fitness for a particular purpose, or non-infringement. Stern Engineering Ltd assumes no responsibility for errors or omissions in the information presented in this document. In no event shall Stern Engineering Ltd be liable for any special, incidental, indirect or consequential damages of any kind, or any damages whatsoever arising out of or in connection with the use or performance of this information. The tradenames, trademarks, logos and service marks presented in this document, including their design, are the property of Stern Engineering Ltd or other third parties and you are not permitted to use them without the prior written consent of Stern Engineering Ltd or such third party as may own them.

# TECHNICAL DATA

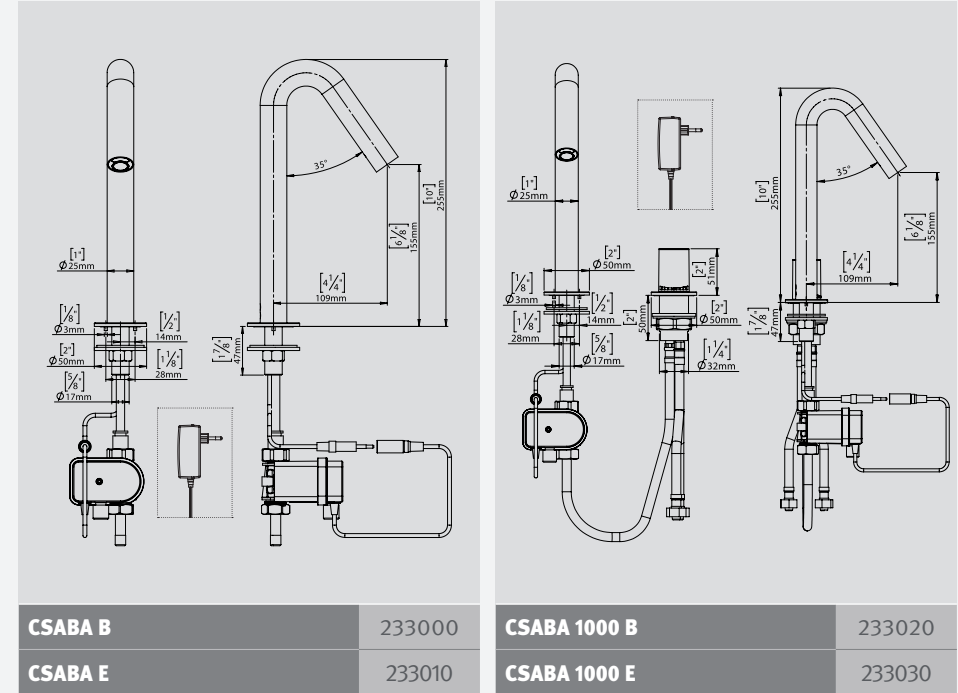

<b>Power supply</b>	Dual Power Input Box. • E version: 9V Transformer • B Version: 9V battery (not included)
<b>Recommended water pressure</b>	0.5-8.0 bar (7-116 PSI) With water pressure of more than 8 bars, use a pressure reducing valve for reduction.
<b>Preset sensor range</b>	100 mm / 39.37" (customizable with optional remote control) Self Adaptive.
<b>Minimum sensor range</b>	30 mm / 1.18"
<b>Maximum sensor range</b>	120 mm / 4.72"
<b>Security time</b>	90 seconds (can be reduced with optional remote control)
<b>Hot water temperature</b>	Max 70°C



# INSTALLATION

## STEP 1 – PREPARATION FOR MOUNTING THE FAUCET

1 Shut off the water supply.

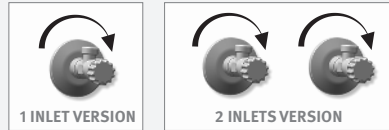

2 Remove the hexagonal nut, disk and washer. Do not remove the O-ring from the base of the faucet.

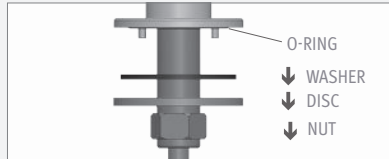

3 For Csaba 1000B/E drill a hole in the counter for the mixing handle. Remove the nut, disk and seal.

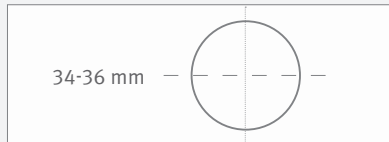

## STEP 2 – INSTALLING THE FAUCET

1 Place the faucet with O-ring into the hole in deck or lavatory. Make sure the O-ring is located between the deck or lavatory and the bottom of the faucet.

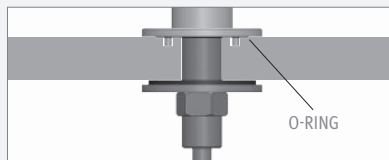

2 Slide the washer, disk and hexagonal nut over the flexible hose and secure the faucet into place.

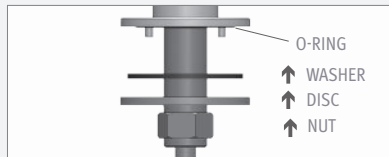

3 For Csaba 1000B/E Place mixer in the hole and secure with nut, disk and seal. Ensure the mixer is aligned properly

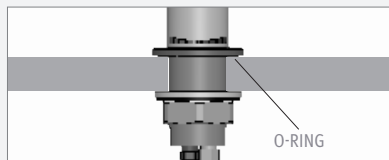

4  
1. Connect hot and cold inlet hoses to the water mains.  
2. Connect the outlet from mixer hose to the Dual Power Input Box

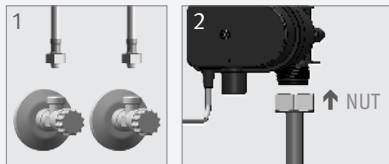

# INSTALLATION

## STEP 3 – CONNECTING THE WATER SUPPLY

NOTE: Flow direction is denoted by the arrow on the solenoid housing.

1 Connect the Nipple and FILTER on the inlet side of the solenoid.

2 Connect the quick connector on the outlet side of the solenoid.

3 Connect the dual power box to the water supply lines.

4 Connect the black flexible tube to the quick connector on the top of the dual power box.

5 For battery versions: Place battery into the Dual Power input box.

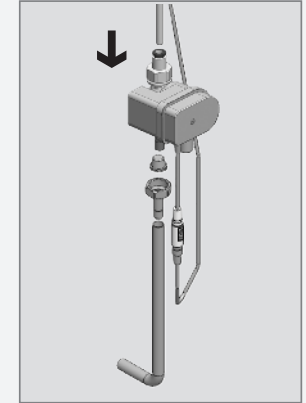

## STEP 4 – CONNECTING THE POWER SOURCE

1 Turn on the central water supply. Check for leaks. Remove the protective sticker from the sensor.

2 Connect the power source.

3 Once the power source is connected, wait 15 seconds to allow the system to set the ideal sensor range. A LED will flash continuously to indicate this adjustment period. The solenoid valve will open for 1 second to indicate that the ideal sensor range was set.



4 If the automatically adjusted sensor range is not satisfactory to your purposes, please refer to the section entitled “Settings adjustment”.

## SETTINGS ADJUSTMENT



### Adjusting the settings with the remote control

If necessary, the sensor settings can be adjusted as following:

Shut off the water supply. In order to adjust the sensor with the remote control, hold the remote control straight in front of the sensor in a distance of about 6-8" (15-20cm). Choose the function you want to adjust by pressing once on one of the function buttons. After pressing once on a specific function button, a quick flashing of the LED at the front of the sensor will occur. At this stage, you can change the setting by pressing the (+) or the (-) buttons, every push will increase or decrease one level. After finishing the adjustment, turn the water supply back on.

## SETTINGS ADJUSTMENT



**DETECTION RANGE:** This faucet was supplied with a self adjusting sensor. The ideal detection range for the specific location will be set automatically.

Only if necessary, use the remote control to adjust the sensor range as follows:

Press the RANGE button. Wait until a quick flashing of the LED in the sensor eye is perceived. Then, press + to increase the range and – to reduce it. Every push will increase or decrease one level.

Note: Once you have changed the detection range with the remote control, the distance will be remembered by the sensor, even if the power source is disconnected. To get back to the self adjustment mode, use the ADJ button only.



**ENTRANCE TO THE SELF ADJUSTMENT MODE:** Check that no objects are in front of the sensor. Press the ADJ button. Once a quick flashing of the LED of the sensor eye is perceived, remove your hand holding the remote control and move away from the sensor area. The ideal sensor range for the specific location will be set automatically. Once the self adjustment has taken place, the solenoid valve will be opened and closed for 1 second as an indication that the ideal sensor range was set and the product is ready for use.



**SECURITY TIME:** The Security time, prevents continuous running of water due to reflections or vandalism. By default, if the sensor is covered for more than 90 seconds the water flow will shut automatically. To resume regular operation any obstruction must be removed.

Press the SEC button. Wait until a quick flashing of the LED in the sensor eye is perceived. Then, press + to increase the security time and – to reduce it.

## SETTINGS ADJUSTMENT



**DELAY IN TIME:** It is recommended to change the delay in time for flush valves for urinals or toilets only.

If required, the delay in time can also be modified in faucets as follows:

Press the IN button. Wait until a quick flashing of the LED in the sensor eye is perceived. Then, press + to increase the delay in time and – to reduce it.



**DELAY OUT TIME:** This button allows modifying the water flow time after the user removes his hands from the faucet. A delay out time close to 0 will save more water. An increased delay out time will make the user experience more comfortable.

If required, the delay out time can be modified as follows:

Press the OUT button. Wait until a quick flashing of the LED in the sensor eye is perceived. Then, press + to increase the delay out time and – to reduce it.



**24 HOUR HYGIENE FLUSH:** This model includes a 24 hours hygiene flush which is disabled. To activate the hygiene flush, press the clock button. Wait until a quick flashing of the LED in the sensor eye is perceived. Then press + to activate the hygiene flush. To disable it again, press – to deactivate it.



**COMFORT FLUSH:** If your model includes a Comfort flush setting, it can be activated by pressing the flush button.

When the button is pressed, one blink of the LED in the sensor eye is perceived. The pre-programmed flush cycle will take place then.

The Comfort flush cannot be interrupted or deactivated by pressing any button until it is over.



**TEMPORARY OFF FUNCTION:** This function is ideal to perform any kind of activity in front of the sensor without operating the system (for example, cleaning).

The faucet will remain shut for 1 minute when this button is pressed once. To cancel this function and to return to normal operation press the On/Off button again or wait 1 minute.



**RESET BUTTON:** This function restores all the factory settings except for the sensor range. If required, press the Reset button and without releasing it, press the + button once.

**NOTE:** To enter the self adjusting mode, use the ADJ button. To change the sensor range, use the RANGE button.

## MAINTENANCE

### Filter cleaning instructions

This tap is provided with a stainless steel filter preventing foreign particles to enter the lines. If the water flow has decreased, this may be because the filter is clogged. The filter can be cleaned as follows:

1. Shut-off the water shut off valve.
2. Disconnect the water supply pipe from the adaptor and disassemble the filter from it.
3. Wash the filter under running water.
4. Reassemble the parts.
5. Restore the incoming water supply.
6. Make sure that there is no water leakage.

### Care and cleaning of chrome and special finishes

DO NOT use steel wool or cleansing agents containing alcohol, acid, abrasives, or the like. Use of any prohibited cleaning or maintenance products or substances could damage the surface of the faucet. For surface cleaning of faucet use ONLY soap and water, then wipe dry with clean cloth or towel. When cleaning bathroom tile, the faucets should be protected from any splattering of harsh cleansers.

If system chemical disinfection is practiced, chlorine can be used (calculated chlorine concentration of 50mg/l maximum in water per one hour dwell time) at service interval frequency.

## BATTERY REPLACEMENT

### Battery models only

When the battery weakens, the LED will blink at a constant rate when the user's hands are within the sensor range. The battery must be replaced within two weeks.

Always use batteries from a reputable source. Poor quality batteries may affect the performance of the product.

### To replace the battery:

Carefully open the dual power input box using the Allen key provided. Remove the old battery and replace it with a new 9V battery (Lithium battery is recommended). Close the box lid and tighten it with the screw.

**Important:** Spent batteries should not be disposed of with normal household waste. Contact your local authority for information on waste disposal and recycling.



## SPARE PARTS LIST

Seals and Screws Kit	07210184
10-Pack Sensor Kit	08008006
10-Pack Solenoid Valve Kit	07232005
Filter	08530013
Dual Power Input Box (excluding solenoid and battery)	06530042
12-Pack 9V Transformer	06540003
Remote Control 13B (Optional)	07100005
Soap & Water Remote Control (Optional)	07100014

## LIMITED WARRANTY

Y. Stern Engineering Ltd. warrants that its electronic products will be free of defects in material and workmanship during normal use for two years from the date the product is purchased.

If a defect is found in normal use, Y. Stern Engineering Ltd. will, at its discretion, repair, provide a replacement part or product, or make appropriate adjustments. Damage caused by accident, misuse, or abuse is not covered by this warranty. Improper care and cleaning will void the warranty. Proof of purchase (original sales receipt) must be provided to Stern Engineering Ltd. with all warranty claims.

Stern Engineering Ltd is not responsible for labor charges, installation, or other incidental or consequential costs other than those noted above. In no event shall the liability of Stern Engineering Ltd. exceed the purchase price of the product.

If you believe that you have a warranty claim, contact your Stern Distributor, Dealer or Plumbing Contractor. Please be sure to provide all pertinent information regarding your claim, including a complete description of the problem, the product, model number, the date the product was purchased, from whom the product was purchased and the installation date. Also include your original invoice.

Y. STERN ENGINEERING AND/OR SELLER DISCLAIM ANY LIABILITY FOR SPECIAL, INCIDENTAL OR CONSEQUENTIAL DAMAGES. This warranty excludes product damage due to installation error, incorrect maintenance, wear and tear, battery, product abuse, or product misuse, whether performed by a contractor, service company, or the consumer. This warranty does not cover product damage caused by the following:

- Incorrect installation.
- Inversions of supply pipes.
- Pressures or temperatures exceeding recommended limits.
- Improper manipulation, tampering, bad or lapsed maintenance.
- Foreign bodies, dirt or scale introduced by the water supply or soap tank.
- Use of the soap outside of viscosity specifications.
- Alteration of the original soap/foam dispenser components (including pipes).

## TROUBLESHOOTING

PROBLEM	INDICATOR	CAUSE	SOLUTION
No water coming out of the faucet:	1. Sensor flashes continuously when user's hands are within the sensor's range.	Low battery.	Replace battery
	2. LED in the sensor does not flash once when user's hands are within the sensor's range.	1. Range is too short.	Increase the range
		2. Range is too long.	Decrease the range
		3. Battery is completely used up	The battery must be replaced.
		4. Unit is in "Security Mode"*	
	3. LED in the sensor flashes once when user's hands are within the sensor's range.	5. Sensor is picking up reflections from the washbasin or another object.	Eliminate cause of reflection.
1. Connectors between the electronic unit and solenoid are disconnected.		Connect the electronic unit connectors to the solenoid.	
		2. Debris or scale in solenoid.	Unscrew solenoid, pull out the plunger and the spring from the solenoid and clean them. Use scale remover material if needed. When replacing the plunger, please make sure that the spring is in vertical position.
3. The central orifice in the diaphragm is plugged or the diaphragm is torn		Clean the orifice or replace diaphragm.	
4. The water supply pressure is higher than 8 bar.		Reduce the supply water pressure.	
5. The water supply pressure is under 8 bars and yet the pressure in the faucet's body is higher. This situation could be caused by a sudden increase in the water supply pressure that the back check prevents from dropping, even after water supply pressure drops under 8 bars.	Shut off water supply and unscrew one of the flexible pipes in order to reduce the pressure that blocks the product.		
Water flow from spout does not stop:	1. Sensor flashes once when user's hands are within the sensor's range.	1. Debris or scale in diaphragm	Clean the orifice or replace diaphragm.
	2. LED in the sensor does not flash once when user's hands are within the sensor's range.	1. Sensor is dirty or covered.**	Clean or eliminate cause of interference.
		2. Sensor is picking up reflections from the washbasin or another object.	Decrease the range or eliminate cause of reflection.
Water flow diminished		Filter or aerator is clogged	Remove, clean, re-install

\* "Security Mode": If the sensor is covered for more than 90 sec. the faucet will automatically shut off water flow.

To return to normal operation remove any blockage.

\*\* In this case, the water flow will stop anyway after 90 seconds because of the security time.



# STERN

STERN ENGINEERING LTD.

777 Passaic Avenue, Clifton NJ, 07012, USA

Tel: +1-973 773 8011 | Fax: +1-973-779-8768

Toll Free: 1-800-4364410

[info@sternfaucets.com](mailto:info@sternfaucets.com) | [tech@sternfaucets.com](mailto:tech@sternfaucets.com)

